

SmartGen

MAKING CONTROL SMARTER

HAT530N ATS CONTROLLER USER MANUAL

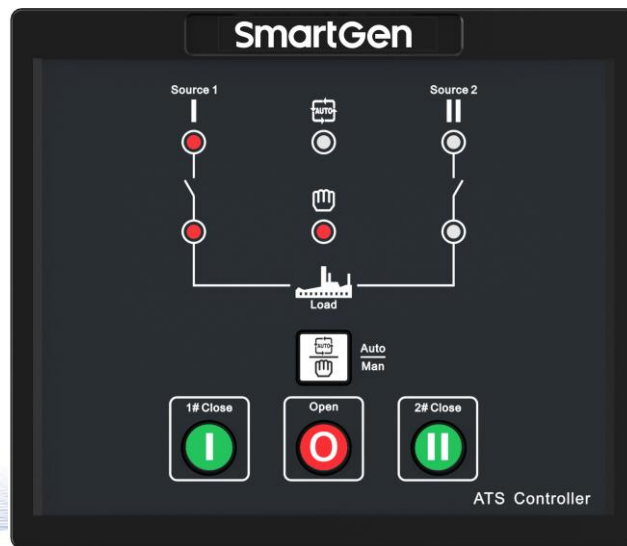

郑州众智科技股份有限公司
SMARTGEN(ZHENGZHOU) TECHNOLOGY CO.,LTD.

SmartGen – make your generator *smart*

SmartGen Technology Co., Ltd.

No.28 Jinsuo Road, Zhengzhou, Henan Province, China

Tel: +86-371-67988888/67981888/67992951

+86-371-67981000(overseas)

Fax: +86-371-67992952

Email: sales@smartgen.cn

Web: www.smartgen.com.cn
www.smartgen.cn

All rights reserved. No part of this publication may be reproduced in any material form (including photocopying or storing in any medium by electronic means or other) without the written permission of the copyright holder.

Applications for the copyright holder's written permission to reproduce any part of this publication should be addressed to Smartgen Technology at the address above.

Any reference to trademarked product names used within this publication is owned by their respective companies.

SmartGen Technology reserves the right to change the contents of this document without prior notice.

Table 1 - Software Version

Date	Version	Note
2016-07-04	1.0	Original release.
2018-05-25	1.1	Modify function of terminal 1 as normally open, and terminal 3 as normally close.
2019-05-22	1.2	Add AtyS d wiring diagram.
2020-04-16	1.3	Add Auto Trans. Auto Restore/Auto Trans. Non-restore function description.
2020-06-03	1.4	1. Due to the change of the capacity of closing and opening relay, the capacity label in the revised manual is consistent with the mask. 2.Add auto trans. auto restore/auto trans. non-restore parameter instructions for panel setting steps.
2020-07-30	1.5	Add 3P3W parameter instructions for panel setting steps. 3P3W is only applicable for AC line voltage 230V power supply system and hardware needs to be customized.
2022-07-26	1.6	Update the manual format; update the logo of SmartGen.
2022-08-23	1.7	Modify the parameter setting of panel operation.

CONTENT

1	OVERVIEW.....	4
2	PERFORMANCE AND CHARACTERISTICS.....	4
3	SPECIFICATION.....	5
4	OPERATING.....	6
4.1	OPERATION PANEL.....	6
4.2	INDICATORS DESCRIPTION.....	6
5	PANEL OPERATION FOR PARAMETTER SETTING.....	7
5.1	BUTTONS AND INDICATORS OF PARAMETER SETTIN.....	7
5.2	PARAMETER SETTING.....	7
6	PARAMETER CONFIGERATION.....	10
6.1	PARAMETERS TABLE.....	10
6.2	OUTPUT FUNCTION DESCRIPTION.....	12
7	OPERATION CONTROL.....	12
8	DESCRIPTION OF CONNECTING TERMINALS.....	13
8.1	BACK PANEL.....	13
8.2	FUNCTION DESCRIPTION OF WIRING TERMINALS.....	14
9	ATS POWER SUPPLY.....	15
10	TYPICAL WIRING DIAGRAM.....	16
11	INSTALLATION.....	18
12	FAULT FINDING.....	19

1 OVERVIEW

The powerful Microprocessor contained within the HAT530N ATS controller allows for precision voltage (2-way 3-phase/single phase) measuring and make accurate judgment on abnormal voltage (power lost, over/under voltage, over/under frequency, loss of phase, phase sequence wrong) and control ATS to transfer after the delay has expired. This controller is suitable for NO Breaking ATS and ONE Breaking ATS. When #1 power is abnormal, the controller will send signal to start genset after the “#1 abnormal delay” has expired. “Three remotes” (remote control, remote measurement and remote communication) functions can be implemented with the help of LINK communication port.

2 PERFORMANCE AND CHARACTERISTICS

Its performance and characteristics are shown as below,

- Measure and display 2-way 3-phase Voltage and Frequency:

1#	2#
Line voltage (Uab, Ubc, Uca)	Line voltage (Uab, Ubc, Uca)
Phase voltage (Ua, Ub, Uc)	Phase voltage (Ua, Ub, Uc)
Frequency Hz	Frequency Hz
- Over/under voltage, loss of phase, phase sequence wrong, over/under frequency protection function. As default, phase reverse sequence protection and over/under frequency protection are disabled; however, users can set the protection function as you need.
- Parameters can be set via PC software using SG72 module (USB to LINK) or other converse module.
- The voltage normal delay of 1# or 2# can be set in (0~60) seconds and the Genset start delay can be set in (0~3600) seconds.
- The voltage abnormal delay of 1# or 2# can be set in (0~60) seconds and the Genset stop delay can be set in (0~3600) seconds.
- “1# Master”, “Auto/Manual”, “Each Backup” and “2# Master” can be set via controller front panel, to realize power supply of 1# master or 2# master or backup method for each other.
- Closing output signal can be set as pulse or as continuous output.
- 2-way N wire isolated design.
- Auto/Manual mode. In manual mode, ATS transfer can be implemented via panel pushbutton.
- LEDs mounted on front panel can clearly show ATS running status.
- Forced Open input port is designed; When the input port is active, the switch will be Breaking position forcedly (works for the ATS with Breaking Position).
- AUX.OUTPUT 1 and AUX.OUTPUT 2 can be configured to make it easy to transfer power supply.
- The output contact capacity of 1# and 2# power supply transfer relay (1# CLOSE, 2# CLOSE, OPEN) is 5A AC250V, volts free contact, can be directly used in driving switch to transfer.
- The output contact capacity of Genset start relay (GENS START) is 7A AC250V/7A DC28V, volts free N/C contact.
- Suitable for various AC systems (3-phase 4-wire, single-phase 2-wire, 2-phase 3-wire and 3-phase 3-wire).
- Modular design, flame retardant ABS plastic shell, pluggable terminal, built-in mounting , compact structure with easy installation.

3 SPECIFICATION

Table 2 – Product Specification

Items	Contents
Operating Voltage	AC170V~277V during AC power L1N1/L2N2 supply.
Power Consumption	<3W (Standby mode: <1W)
AC Voltage Input	
3P4W (ph-N)	AC170V~AC277V(ph-N)
1P2W (ph-N)	AC170V~AC277V (ph-N)
2P3W (ph-N)	AC170V~AC277V(ph-N)
3P3W (ph-ph)	AC170V~AC277V(ph-ph) (Hardware needs to be customized)
Rated Frequency	50/60Hz
1# Close Relay Output	10A AC250V Volts free output
2# Close Relay Output	10A AC250V Volts free output
Open Relay Output	10A AC250V Volts free output
AUX.OUTPUT 1	16A AC250V Volts free output
AUX.OUTPUT 2	16A AC250V Volts free output
Gen Start Relay	7A AC250V Volts free output
1# Close Input	COM2 connect is active.
2# Close Input	COM2 connect is active.
Forced Breaking Input	COM2 connect is active.
Communication	LINK interface, MODBUS Protocol
Case Dimensions	139mmx120mmx50mm
Panel Cutout	130mmx111mm
Working Temperature	(-25~+70)°C;
Working Humidity	(20~93)%RH
Storage Temperature	(-30~+80)°C
Protection Level	IP65 Gasket: when waterproof gasket is installed between controller and control window.
Insulation Strength	Apply AC1.5kV voltage between high voltage terminal and low voltage terminal and the leakage current is not more than 3mA within 1min.
Weight	0.51kg

4 OPERATING

4.1 OPERATION PANEL

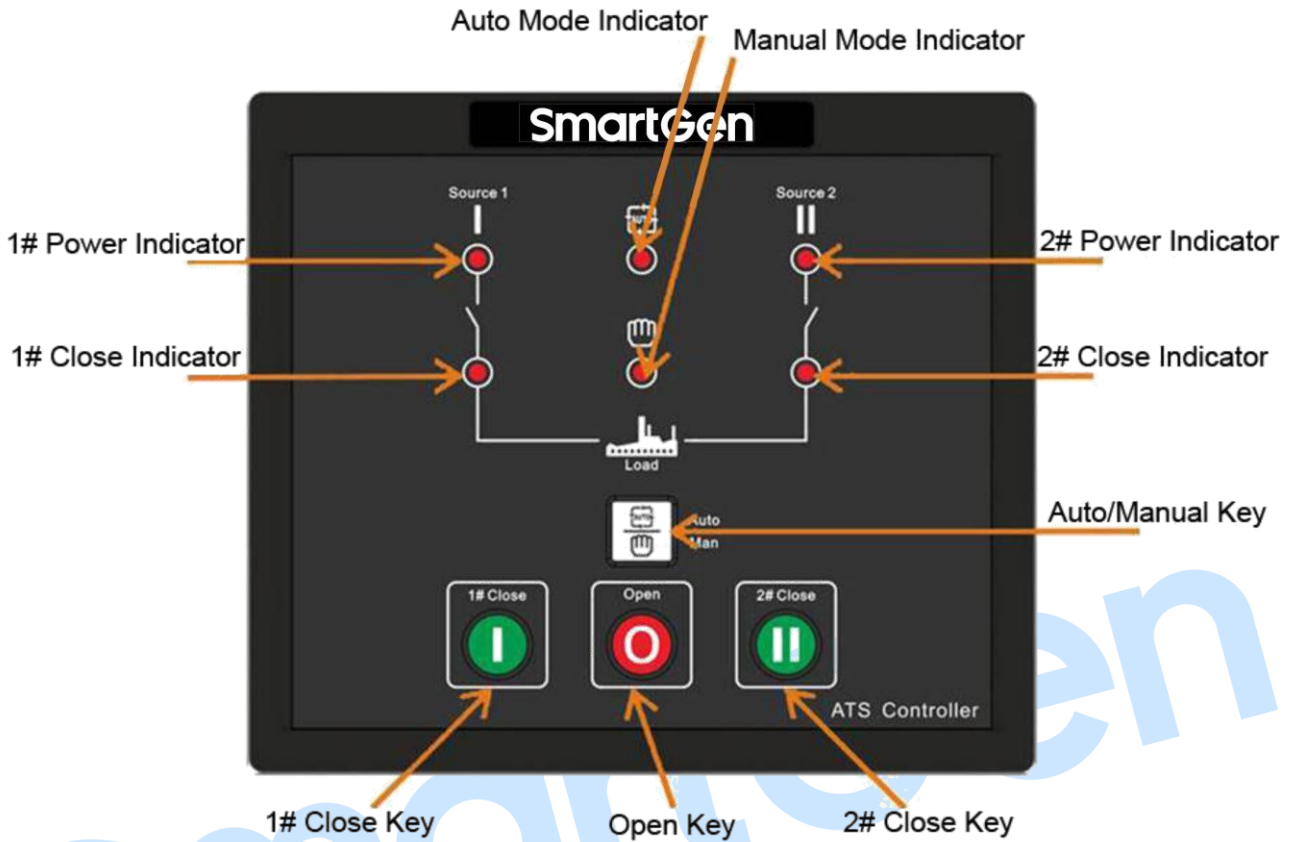

Fig.1 – HAT530N Panel Drawing

4.2 INDICATORS DESCRIPTION

Table 3 – Indicator Function Description in Normal Testing Mode

Items	Description
1# Power Indicator	It is illuminated when 1# power is normal; flashing when 1# power state is abnormal; off when there is no 1# power.
2# Power Indicator	It is illuminated when 2# power is normal; flashing when 2# power state is abnormal; off when there is no 2# power.
1# Close Indicator	It is illuminated when 1# power auxiliary contactor is active while off when it is deactivated.
2# Close Indicator	It is illuminated when 2# power auxiliary contact is active while off when it is deactivated.
Auto Mode Indicator	It is illuminated when the controller is in auto mode while off the controller is in manual mode.
Manual Mode Indicator	It is illuminated when the controller is in manual mode while off the controller is in auto mode.

▲ NOTE: More details please refer to the following description of “Panel Button Operation”.

5 PANEL OPERATION FOR PARAMETER SETTING

5.1 BUTTONS AND INDICATORS OF PARAMETER SETTING

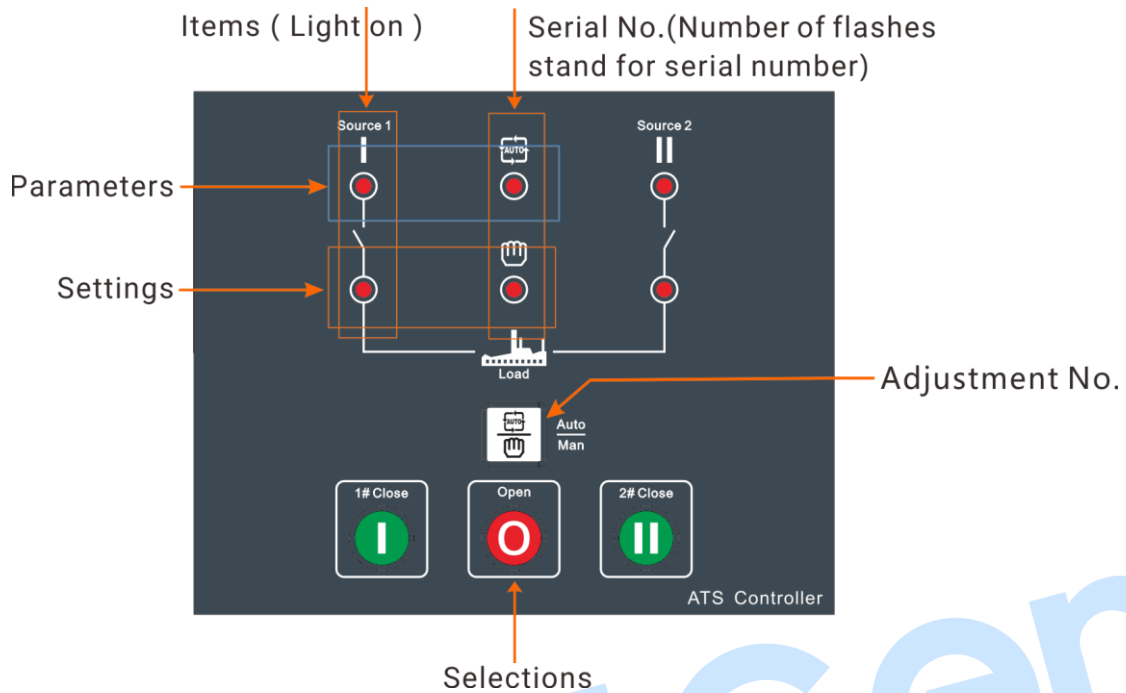











Fig.2 – Buttons and Indicators of Parameter Setting

5.2 PARAMETER SETTING

- Pressing and holding the  button for more than 3s, all LEDs are illuminated to enter into lamp test mode; hold  button and do not release, after 7s to enter into parameter No.1 to check the status, all the indicators of parameter items are all illuminated, the indicators of parameter No. and setting No. are flashes at a certain frequency;
- Press  button to enter into parameter No.2 to check the status, and it circles in order;
- If set AC system as 2P3W, press  button, the indicator of parameter items is distinguished while the indicator of parameter items is illuminated, then enter into the setting status;
- Press  button to adjust the number to set parameter, press  button and the setting No. will increase 1. After the parameter setting is done, then press  button to confirm and save, and the indicator of parameter items is illuminated while the indicator of setting items is distinguished. Go back to the current parameter No. to check the status;
- If the parameter is set to the last No.6 of delay adjustment, press  button to select the item, press  button to adjust the number, the indicator of setting items flashes once,

press  button to save the delay adjustment. All the indicators flash 5 times and return to the normal test mode.

- f) If there is no need to set the parameter, press  button and hold it for more than 3s, all the indicators will flash 5 times and return to the normal test mode;

Table 4 – Panel Parameter Setting

Parameter No.	Setting Items	Settings & No.	Default	Parameter Indicators	Setting Indicators
1	Main Use	1 : 1# Power Supply	1 : 1# Power Supply	Flash once	Flash once
		2 : 2# Power Supply			Flash twice
		3: Mutual Back-up			Flash 3 times
2	AC Line system	1: 3P4W	1: 3P4W	Flash twice	Flash once
		2: 2P3W			Flash twice
		3: Single phase			Flash 3 times
		4: 3P3W			Flash 4 times
3	Auto Trans. Auto Restore	1: Auto trans. Non restore	2: Auto trans. auto restore	Flash times 3	Flash once
		2: Auto trans. auto restore			Flash twice
4	Remote Adjustment	1: Remote adjustment enable	1: Remote adjustment enable	Flash times 4	Flash once
		2: Remote adjustment disable			Flash twice
5	Delay Value of Factory Default			Flash times 5	Flash once
6	Delay Adjustment	1: 1# Power abnormal delay	Adjust the potentiometer on back panel	Flash times 6	Flash once
		1: 2# Power abnormal delay			

Note 1: Each time the controller is power on, the main use status of the controller can be judged by the following three conditions.

If the 1# power indicator flashes 3 times rapidly, the #1 power is main use.

If the 2# power indicator flashes 3 times rapidly, the #2 power is main use.

If 1# & 2# power indicators flash 3 times rapidly at the same time, they are mutual- backup.

Note 2: Each time the controller is power on, the AC line system of the controller can be judged by the following four conditions.

If 1# close indicator is light on, it is 1P2W;

If 1# close indicator, manual status indicator and 2# indicator are all illuminated, it is 3P4W.

If 1# close indicator and manual status indicator are illuminated, it is 2P3W.

If 2# close indicator and manual status indicator are illuminated, it is 3P3W.

Note 3: Each time the controller is power on, the auto trans. auto restore/auto trans. non-restore status of the controller can be judged by the following 2 conditions.

If 1# power indicator and 1# close indicator flash 3 times rapidly at the same time, it is auto trans. non-auto restore status.

If 2# power indicator and 2# close indicator flash 3 times rapidly at the same time, it is auto trans. auto restore status.

Note 4: When the remote adjustment is disabled, PC cannot write parameter configuration to host computer.

Note 5: The factory default value is 1# power and 2# power abnormal delay for 5s, the genset will stop delay for 90s.

Note 6: 1# power abnormal delay: adjust the potentiometer (on back panel) of "1# power normal delay"; 2# power abnormal delay: adjust the potentiometer (on back panel) of "2# power normal delay"; the set value of 1# power normal delay should greater than or equal to the set value of 1# power abnormal delay, otherwise 1# power normal delay value will be forced set to the set value of 1# power abnormal delay; the set value of 2# power normal delay should greater than or equal to the set value of 2# power abnormal delay, otherwise 2# power normal delay value will be forced set to the set value of 2# power abnormal delay;

Note 7: When parameter is set to restore the factory default setting and delay adjustment, press  button and press



button again; when the indicator of setting item No. flashes, press  button to save the configuration.

6 PARAMETER CONFIGURATION

6.1 PARAMETERS TABLE

Table 5 – Parameters Setting Table

No.	Item	Range	Default	Description
01	1# Normal Delay	(0-60)s	Can be set via controller potentiometer	It is the delay of #1 power from voltage abnormal to voltage normal. Generally, it is 10s.
02	1# Abnormal Delay	(0-60)s	5	It is the delay of #1 power from voltage normal to voltage abnormal.
03	2# Normal Delay	(0-60)s	Can be set via controller potentiometer	It is the delay of #2 power from voltage abnormal to voltage normal. Generally, it is 10s.
04	2# Abnormal Delay	(0-60)s	5	It is the delay of #2 power from voltage normal to voltage abnormal.
05	Close Delay	(0-20)s	5	Closing relay output pulse. If set as zero, it is continuous output.
06	Open Delay	(1-20)s	5	Open relay output pulse.
07	Transfer Interval	(0-60)s	1	It is the delay from 1# power open to 2# power close or from 2# power open to 1# power close.
08	Exceed Transfer	(0-20.0)s	0.0	It is the extra output delay of the close relay after the closing signal has received.
09	Start Delay	(0-3600)s	1	When voltage is abnormal, start delay begins; start signal is initiated after the delay has expired.
10	Stop Delay	(0-3600)s	90	When starting, if the mains voltage is normal, stop delay begins; stop signal is initiated after the delay has expired.
11	AC System	(0-3)	0	0. 3-phase 4-wire 1. 2-phase 3-wire 2. Single phase 3. 3-phase 3-wire
12	Rated Volt	(100-240)V	230	AC system rated voltage.
13	Rated Frequency	(50.0-60.0) Hz	50.0	To offer standards for detecting of over/under frequency.
14	Over Volt Enable	(0-1)	1	0: Disable; 1: Enable
15	Over Voltage	(100-120)%	115	Voltage upper limit; it is abnormal when the voltage has exceed the set value.
16	Over Volt Return	(100-120)%	113	Voltage upper limit return value; it is normal

No.	Item	Range	Default	Description
				only when the voltage fallen below the set value.
17	Under voltage	(70-100)%	75	Voltage lower limit; it is abnormal when the voltage has fallen below the set value.
18	Under Volt Return	(70-100)%	77	Voltage lower limit return value; it is normal only when the voltage has exceeded the set value.
19	Over Freq. Enable	(0-1)	0	0: Disable; 1: Enable
20	Over Frequency	(100-120)%	110	Frequency upper limit; it is abnormal when the frequency has exceed the set value.
21	Over Freq. Return	(100-120)%	104	Frequency upper limit return value; it is normal only when the frequency fallen below the set value.
22	Under Freq. Enable	(0-1)	0	0: Disable; 1: Enable
23	Under Frequency	(80-100)%	90	Frequency lower limit; it is abnormal when the frequency has fallen below the set value.
24	Under Freq. Return	(80-100)%	96	Frequency lower limit return value; it is normal only when the frequency has exceeded the set value.
25	Loss of Phase	(0-1)	1	0: Disable; 1: Enable
26	Reverse Phase Sequence	(0-1)	0	0: Disable; 1: Enable
27	Master-Slave Set	(0-2)	0	0. 1# Master; 1. 2# Master; 2. Each Backup
28	Auto Trans. Auto Restore Set	(0-1)	1	0: Auto Trans. Non Restore 1: Auto Trans. Auto Restore
29	Neutral Position	(0-1)	0	0. One Breaking; 1. No Breaking
30	Aux. Output 1	(0-23)	20	More details please refer to the following OUTPUT FUNCTION DESCRIPTION
31	Aux. Output 2	(0-23)	23	More details please refer to the following OUTPUT FUNCTION DESCRIPTION

NOTE1: Parameters above are configured via PC software of SmartGen. The PC programming connection is to use LINK interface of SG72 module connecting with LINK interface of controller.

NOTE2: "1# Normal Delay" and "2# Normal Delay" can be set only via the potentiometer which locates nearby the back panel terminal. "1# Abnormal Delay" and "2# Abnormal Delay" can be set via the PC software or potentiometer which locates nearby the back panel terminal. AC system and priority selection can be set via panel button or PC software while other parameters can be set via PC software only.

NOTE3: 1# Normal Delay set value must be no less than 1# Abnormal Delay, otherwise, 1# Normal Delay set value will be forced to set as 1# Abnormal Delay set value. 2# Normal Delay set value must be no less than 2# Abnormal Delay, otherwise, 2# Normal Delay set value will be forced to set as 2# Abnormal Delay set value. If motor driving type ATS (e.g. SOCOMEC VS) is applied, the Close delay and Open delay must be no less than 5s; If magnet driving type ATS (e.g. SOCOMEC ATySM3s) is applied, the Exceed Transfer delay must be set as 0.

NOTE4: "Priority Select" in last version is changed to "Master-Slave Set"; Set contents "0: 1# Priority; 1: 2# Priority; 2:

No Priority" are changed to "0: 1# Master; 1: 2# Master; 2: Each Backup".

6.2 OUTPUT FUNCTION DESCRIPTION



Table 6 – Output Function Description

Items	Description
00. Not used	Invalid.
01. 1# Normal volt	It will output when 1# voltage is normal.
02. 1# Abnormal volt	It will output when 1# voltage is abnormal.
03. 2# Normal volt	It will output when 2# voltages is normal.
04. 2# Abnormal volt	It will output when 2# voltages is abnormal.
05. 1#2# Abnormal volt	It will output when 1#2# voltages are abnormal simultaneously.
06. Auto Mode	In will output in automatic mode.
07. Manual Mode	In will output in manual mode.
08. Gens start (N/O)	When generator starts output (Relay closed).
09. Gens start (N/C)	When generator starts output (Relay released).
10. 1# Close Output	1# Switch ON signal output.
11. Open Output	Switch OFF signal output.
12. 2# Close Output	2# Switch ON signal output.
13. Reserved	
14. Reserved	
15. Reserved	
16. 1# Close Status Output	The close status of 1# switch.
17. 2# Close Status Output	The close status of 2# switch.
18. Reserved	
19. Reserved	
20. ATS Power A Phase	ATS power supply.
21. ATS Power B Phase	
22. ATS Power C Phase	
23. ATS Power N Phase	

7 OPERATION CONTROL

When controller is running, pressing  key can set the controller as Auto mode or Manual mode (indicated by automatic and manual indicators).

In Auto mode, controller can automatically transfer the load to 1# or 2# power. When it is set to Auto Trans. Auto Restore, master power is normal, and controller will transfer to master power end in priority; When it is set to Auto Trans. Non Restore, controller only transfers to backup power, and master power transfer can only be controlled manually. Each Backup is for two powers to be backup; when 1# power is abnormal, 2# is normal, then switch will transfer to 2# power supply, and vice versa. When it is set to Each Backup, controller will not detect Auto Trans. Auto Restore setting.

In Manual mode, press  key, load will be transferred to 1# power supply; press  to disconnect load supply; press  key, load will be transferred to 2# power supply.

8 DESCRIPTION OF CONNECTING TERMINALS

8.1 BACK PANEL

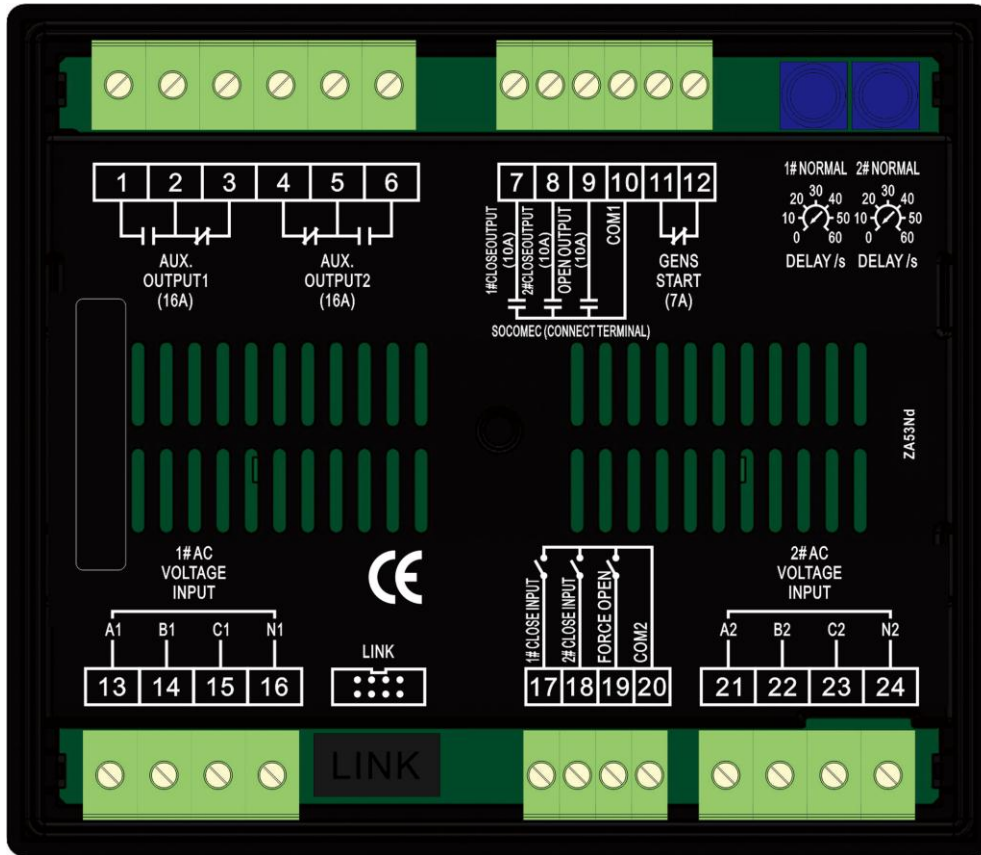

Fig. 3 – HAT530N Rare Panel Drawing

8.2 FUNCTION DESCRIPTION OF WIRING TERMINALS

Table 7 - Terminal Function Table

No.	Items	Description	Remark
1	Aux. Output 1	NO	Default: ATS Power A Phase Volt-free relay contact output; Rated 16A.
2		COM	
3		NC	
4	Aux. Output 2	NC	Default: ATS Power N Phase Volt-free relay contact output; Rated 16A.
5		COM	
6		NO	
7	1# Close Output	Volt-free relay contact output;	Normally Open Output; Rated 10A.
8	2# Close Output	Volt-free relay contact output;	Normally Open Output; Rated 10A.
9	Open Output	Volt-free relay contact output;	Normally Open Output; Rated 10A.
10	COM1	Output COM of close switch and open switch	COM1
11	GEN Start	Volt-free relay contact output;	Normally Close Output; Rated 7A.
12			
13	A1	1# AC 3-phase 4 wire voltage input	For single phase, only connect A1, N1.
14	B1		
15	C1		
16	N1		
17	1# Close Input	Detection of 1# ATS closing status; auxiliary contact input	Connect COM2 is active.
18	2# Close Input	Detection of 2# ATS closing status; auxiliary contact input	Connect COM2 is active.
19	Force Open	When active, the ATS is in Neutral Position.	Connect COM2 is active.
20	COM Port	Input COM	COM2
21	A2	2# AC 3-phase 4 wire voltage input	For single phase, only connect A2, N2.
22	B2		
23	C2		
24	N2		
LINK	Communication Port	Communicate with PC/Program update	

9 ATS POWER SUPPLY

The power of ATS is supplied by controller, as long as one power is normal, this can ensure ATS power supply normally and can be transferred properly.

Users should select power supply voltage (phase voltage or line voltage) based on ATS type. If choose phase voltage, connect the phase voltage of 1# and 2# (e.g. A phase) to normally close (Pin3) and normally open (Pin1) contact of auxiliary output 1; connect N phase of 1# and 2# to normally close (Pin4) and normally open (Pin6) contact of auxiliary output 2. And then connect the common output of auxiliary output 1 and auxiliary output 2 to ATS power supplies. When controller power is ON, the default configuration of auxiliary output 1 is "ATS power A" while auxiliary output 2 is "ATS power N". If the ATS power supplied by Line Voltage, same procedures as above but change phase N to phase voltage and the auxiliary output 2 should be configured as "ATS power B". Parameters can be set via PC software. Wiring diagrams are shown as following:

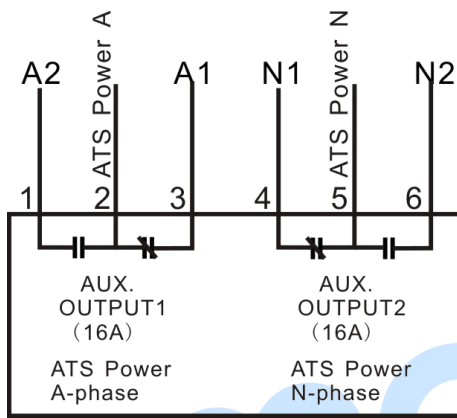

Fig. 4 - ATS phase voltage power supply

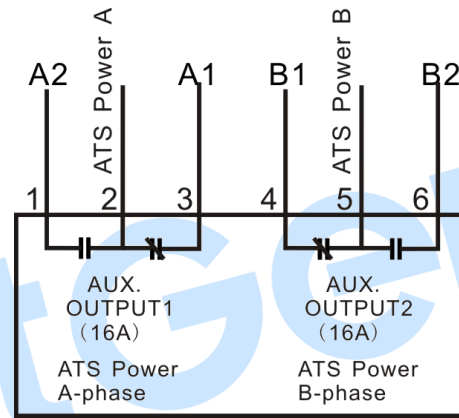

Fig. 5 - ATS line voltage power supply

NOTE: If there is no need to control ATS Power Supply, then the above terminals are not connected and the Auxiliary Output 1 and Auxiliary Output 2 should be set as "Not used". If the Auxiliary output 1 and Auxiliary Output 2 are used for something function other than the "ATS Power Supply", corresponding function items should be set.

10 TYPICAL WIRING DIAGRAM

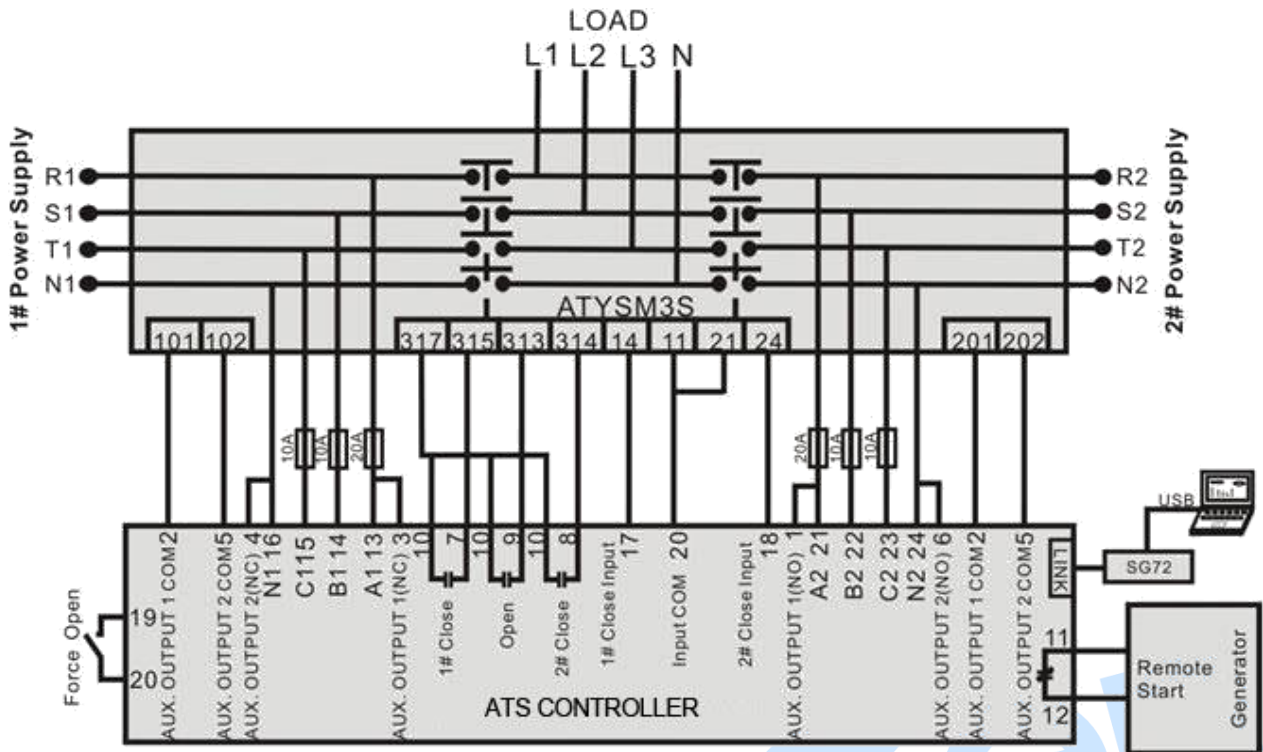

Fig. 6 - ATySM3s Wiring Diagram

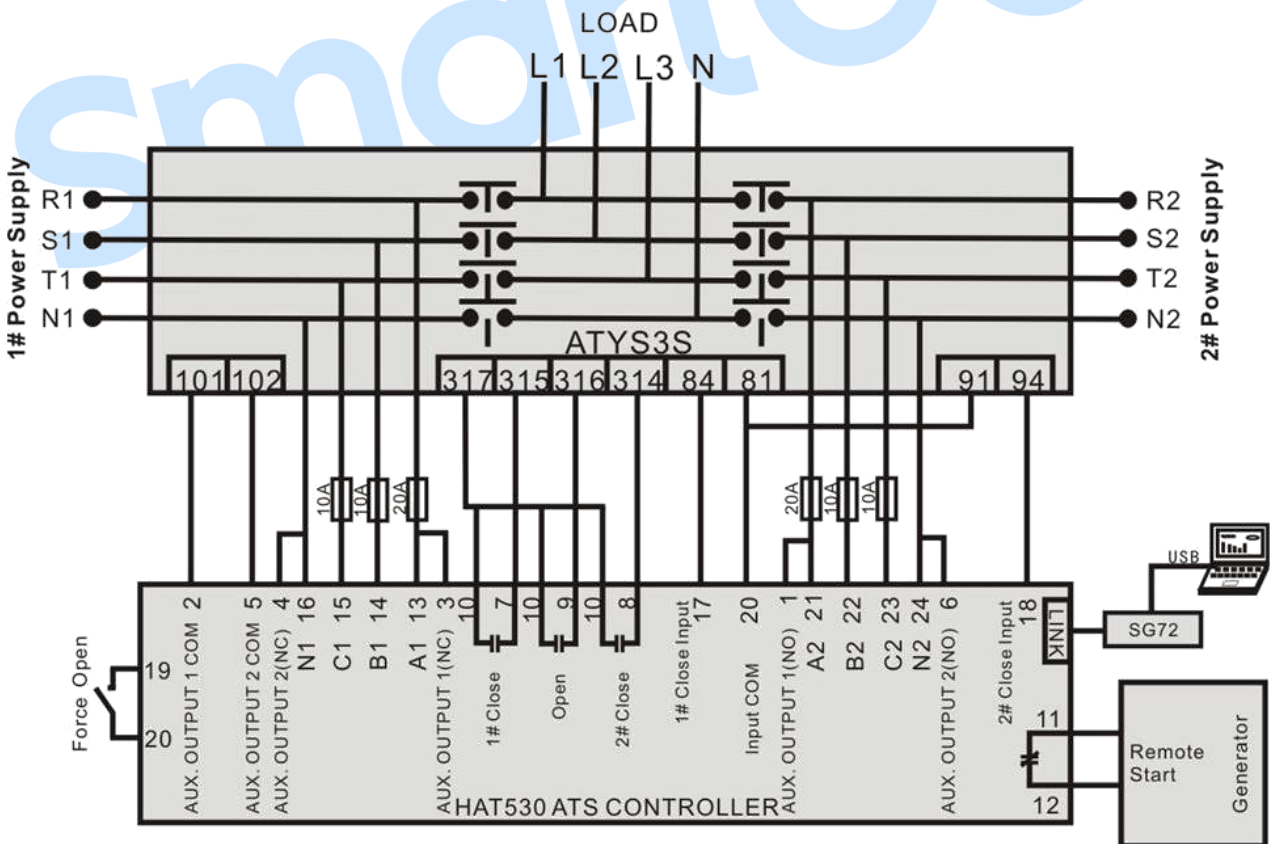

Fig. 7 - ATyS3s Wiring Diagram

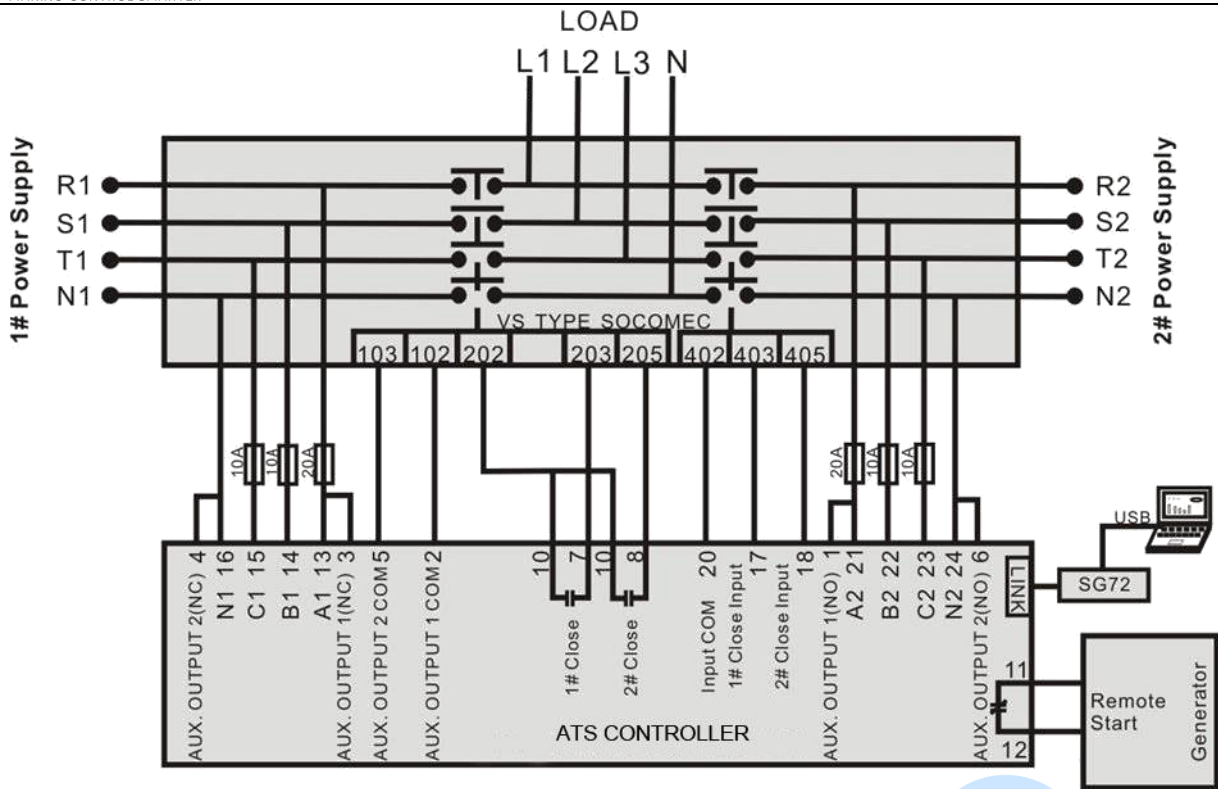

Fig. 8 - SOCOMEC VS Wiring Diagram

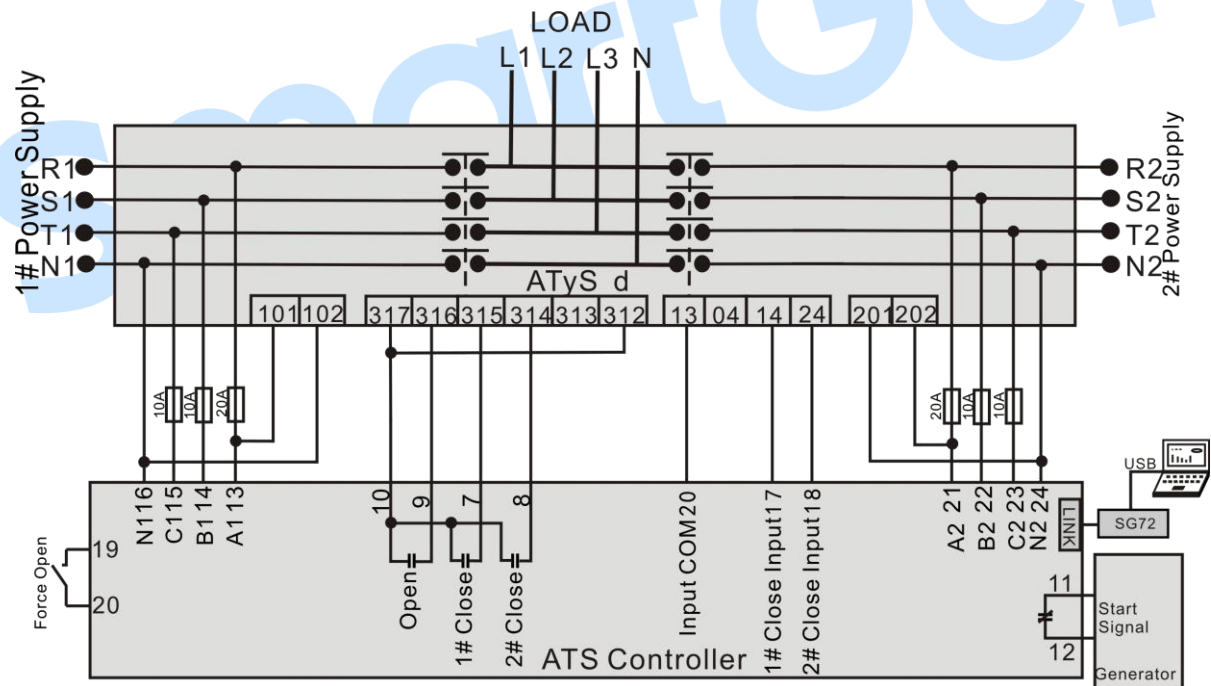

Fig. 9 – ATyS d Wiring Diagram

NOTE: The diagram is for reference only. The actual wiring shall follow the ATS instruction. Users should choose proper fuse capacity according to the actual power consumption. If SOCOMEC VS is applied, the Close delay and Open delay must be no less than 5s (Default: 5s).

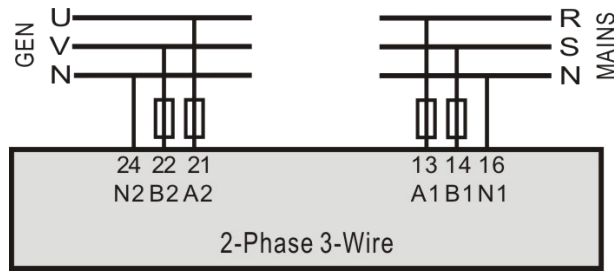

Fig. 10 - 2-phase 3-wire Wiring Diagram

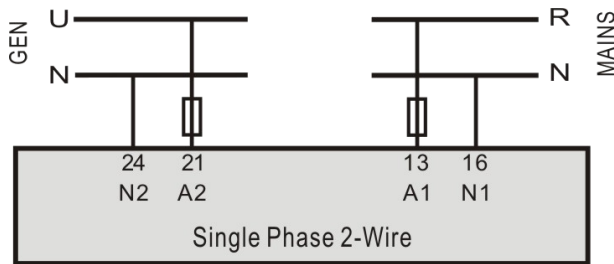

Fig. 11 - Single phase 2-wire Wiring Diagram

NOTE: Above pictures take the AC 220V voltage as example. If AC 110V voltage is applied in actual use, please contact with SmartGen technical staff to get the specific wiring methods.

11 INSTALLATION

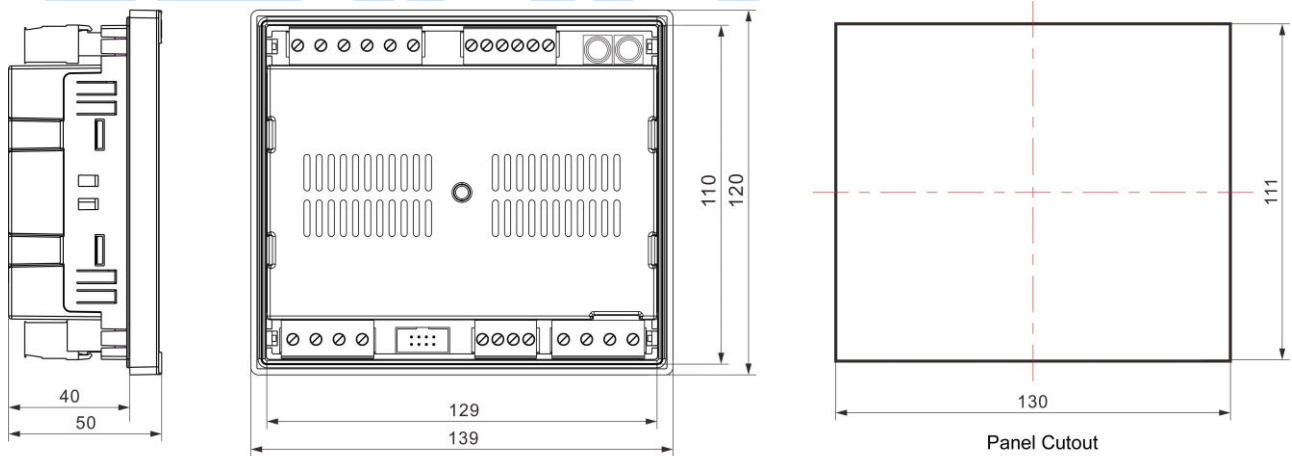

Fig. 12 - Installation Dimensions

12 FAULT FINDING

Table 8 – Fault Finding

Symptom	Possible Solutions
Controller no response with power.	Check controller wiring.
ATS not transfer	Check ATS; Check the connection wirings between the controller and the ATS.
Electrical parameters detection error	Check controller wiring; Modify electrical parameters detection value.
PC software communication failure	Check communication port setting and connections.

